

### Basics

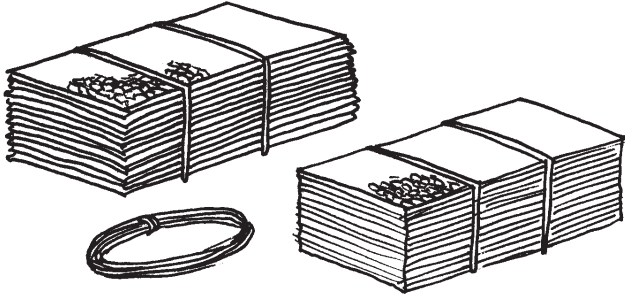

Mattress bases and lids are supplied in flat pack bundles bound with a tie wire. Snip the tie wire and lift off the individual baskets as needed.  
*N.B. Take care when unravelling flat packed bundle as wire could spring out when unravelled.*  
 (Coils of tying wire will also be delivered.)

Mattress stone should be a hard, durable, non-friable material. The size of the stone should conform to Class 6G, also known as 4-6 inch at quarries. The rock sizes should range from approx. 150mm down to 75mm, but not greater than 2/3 mattress thickness.

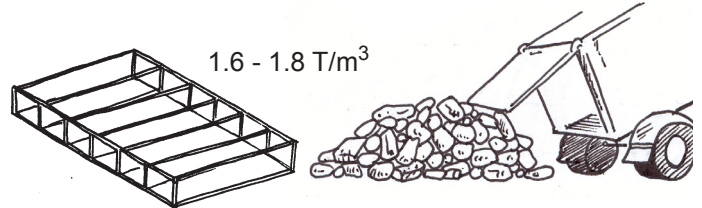
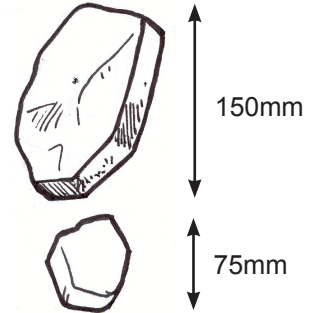

### Assembly

1

N.B. Appropriate Personal Protective Equipment PPE, such as goggles and gloves, should be used. Open out the flat pack mattress on a hard, level surface. Fold open all panels and stamp flat.

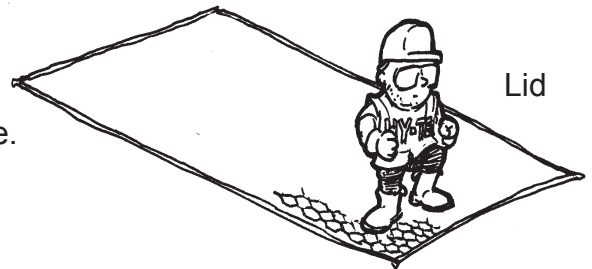

2

Next fold up the side panels to meet the end panels. The mattresses have a thicker wire around the edge of each panel. These thicker wires should be twisted together at the panel corners which meet. Then the panel sides laced together with continual lengths of tying wire.

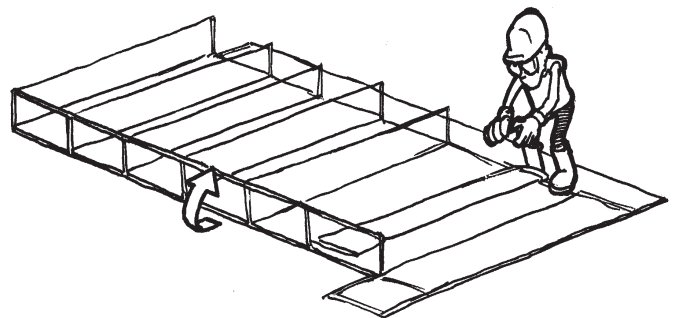

Tip: Use a Stihl saw to cut once through the tying wire. This will give you 1m workable lengths of tying wire.

It is essential when lacing the adjacent mesh panels together that continual lengths of tying wire are used NOT single twist ties.

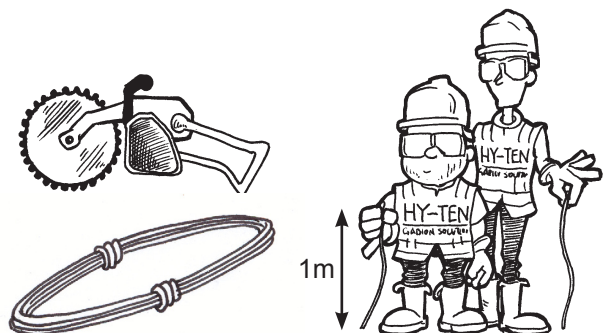

### 3

#### Lacing panels together:

Using approx. 1m lengths of tying wire secure an end to the thicker top wires then lace it through the mesh openings in a single turn, double turn manner repeating every 75mm. Tug the tying wire during the lacing to ensure a good, tight seam.

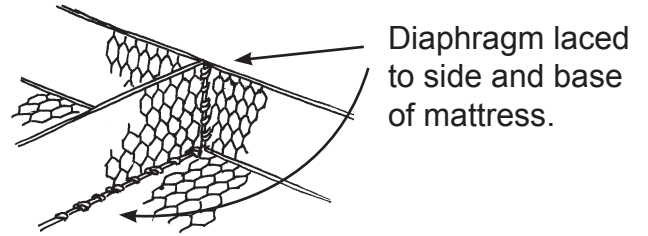

After lacing all the external joints do the internal diaphragms of the mattress.

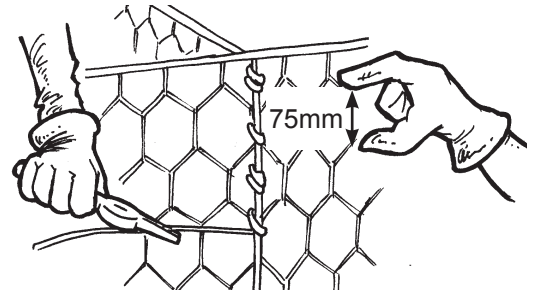

### 4

Once you have a suitable run of empty mattresses side by side, lace together the empty cages along the common joints.

Mattresses placed on slopes should be filled from the bottom to the top. The internal diaphragms should be kept taut during filling to enable better connection with lid panel. This can be done by putting stakes through the corners of the mattress.

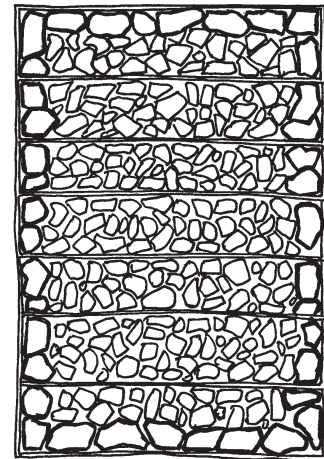
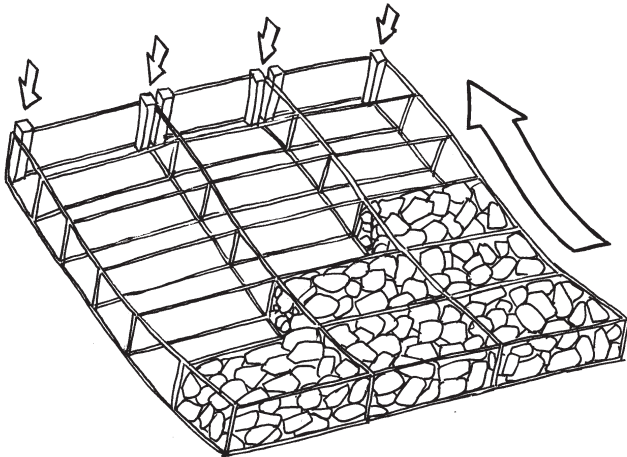

### 5

#### Filling mattresses

Largest stones should be used around the sides with the top face hand placed to give an attractive appearance. Overfill the top of the mattresses by approx. 25mm before fixing the lid at one end.

Then stretch the lid to fix the other end before doing the same stretching and lacing along the sides. Lastly lace the lid to the top of the internal diaphragms.

Your mattress basket is now complete.

